

MENGG366 SYSTEM DYNAMICS AND CONTROL

LABORATORY 8: System Frequency of Second Order System

In this laboratory experiment , we shall obtain the response of a typical second-order control system to a step input.

In terms of damping ratio (ζ) and natural frequency (ω_n), the system shown in figure 1 , and the closed loop transfer function $C(s)/R(s)$ given by the equation 1

$$\frac{C(s)}{R(s)} = \frac{\omega_n^2}{s^2 + 2\zeta\omega_n s + \omega_n^2} \quad 1$$

This form is called the *standard form* of the second-order system.

The dynamic behavior of the second-order system can then be description in terms of two parameters ζ and ω_n .

We shall now solve for the response of the system shown in figure 1, to a unit-step input. We shall consider three different cases: the underdamped ($0 < \zeta < 1$) , critically damped ($\zeta = 1$), and overdamped ($\zeta > 1$)

1) Underdamped Case ($0 < \zeta < 1$) :

In this case, the closed-loop poles are complex conjugates and lie in the left-half s plane. The $C(s)/R(s)$ can be written as

$$\frac{C(s)}{R(s)} = \frac{\omega_n^2}{(s + \zeta\omega_n + j\omega_d)(+\zeta\omega_n - j\omega_d)} \quad 2$$

Where $\omega_d = \omega_n\sqrt{1 - \zeta^2}$, the frequency ω_d is called damped natural frequency. For a unit step-input, $C(s)$ can be written

$$C(s) = \frac{\omega_n^2}{s(s^2 + 2\zeta\omega_n s + \omega_n^2)} \quad 3$$

By apply the partial fraction expansion and the inverse Laplace transform for equation 3, the response can give by

$$c(t) = 1 - \frac{e^{-\zeta\omega_n t}}{\sqrt{1 - \zeta^2}} \sin\left(\omega_d t + \tan^{-1}\left(\frac{\sqrt{1 - \zeta^2}}{\zeta}\right)\right) \quad 4$$

If the damping ratio ζ is equal to zero, the response becomes undamped and oscillations continue indefinitely. The response $c(t)$ for the zero damping case may be obtained by substituting $\zeta = 0$ in Equation 4, yielding

$$c(t) = 1 - \cos \omega_n t \quad 5$$

2) Critically Damped Case ($\zeta = 1$)

If the two poles of $C(s)/R(s)$ are equal, the system is said to be a critically damped one. For a unit-step input, $R(s) = 1/s$ and $C(s)/$ can be written

$$\frac{C(s)}{R(s)} = \frac{\omega_n^2}{s(s + \omega_n)^2} \quad 6$$

By apply the partial fraction expansion and the inverse Laplace transform for equation 6, the response can give by

$$c(t) = 1 - e^{-\omega_n t}(1 + \omega_n t) \quad 7$$

3) Overdamped Case ($\zeta > 1$):

In this case, the two poles of $C(s)/R(s)$ are negative real and unequal. For a unit-step input, $R(s) = 1/s$ and $C(s)$ can be written

$$\frac{C(s)}{R(s)} = \frac{\omega_n^2}{s(s + \zeta\omega_n + \omega_n\sqrt{\zeta^2 - 1})(+\zeta\omega_n - \omega_n\sqrt{\zeta^2 - 1})} \quad 8$$

By apply the partial fraction expansion and the inverse Laplace transform for equation 6, the response can give by

$$c(t) = 1 + \frac{\omega_n}{2\sqrt{\zeta^2 - 1}} \left(\frac{e^{-s_1 t}}{s_1} - \frac{e^{-s_2 t}}{s_2} \right) \quad 9$$

$$s_{1,2} = \zeta \pm \sqrt{\zeta^2 - 1}$$

Thus, the response $c(t)$ includes two decaying exponential terms.

A family of unit-step response curves $c(t)$ with various values of z is shown in Figure1 , where the abscissa is the dimensionless variable $\omega_n t$.

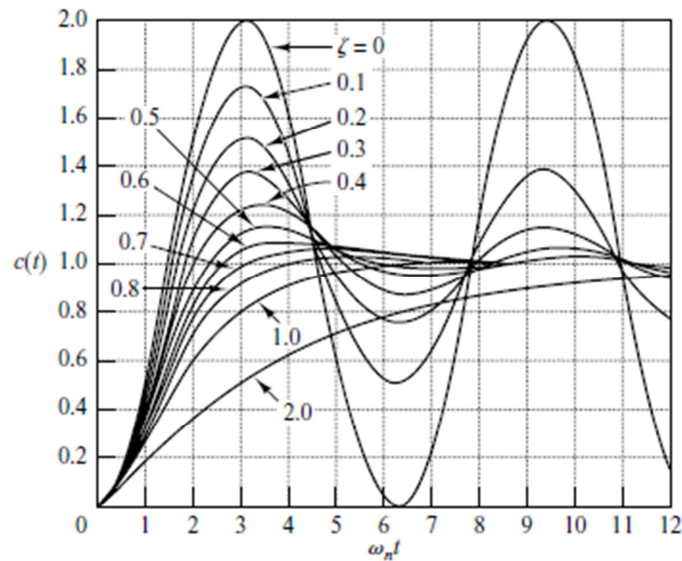

Figure 1: Unit step response curves of the system

1. Definition of Transient-Response Specification:

Frequently, the performance characteristics of a control system are specified in terms of the transient response to a unit-step input, since it is easy to generate and is sufficiently drastic. (If the response unit step input is known, it is mathematically possible to compute the response to any input.)

The transient response of a system to a unit-step input depends on the initial conditions. For convenience in comparing transient responses of various systems, it is a common practice to use the standard initial condition that the system is at rest initially with the output and all time derivatives thereof zero. Then the response characteristics of many systems can be easily compared.

The transient response of a practical control system often exhibits damped oscillations before reaching steady state. In specifying the transient-response characteristics of a control system to a unit-step input, it is common to specify the following:

1. Delay time, t_d
2. Rise time, t_r
3. Peak time, t_p
4. Maximum overshoot, M_p
5. Settling time, t_s

These specifications are defined in what follows and are shown graphically in Figure 2.

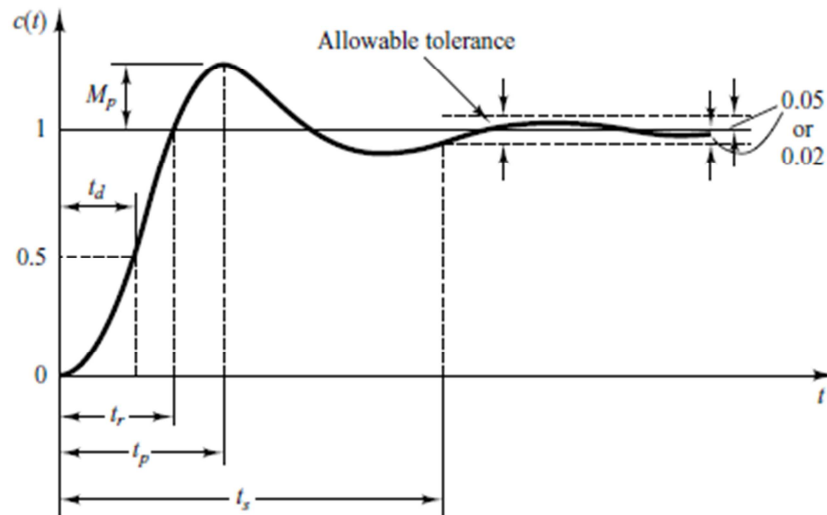

Figure 2: Step response specification

These specifications are defined in what follows and are shown graphically in Figure 2.

1. **Delay time, t_d :** The delay time is the time required for the response to reach half the final value the very first time.

2. **Rise time, t_r :** The rise time is the time required for the response to rise from 10% to 90%, 5% to 95%, or 0% to 100% of its final value. For underdamped second order systems, the 0% to 100% rise time is normally used. For overdamped systems, the 10% to 90% rise time is commonly used.

3. **Peak time, t_p :** The peak time is the time required for the response to reach the first peak of the overshoot.

4. **Maximum overshoot, M_p :** The maximum overshoot is the maximum peak value of the response curve measured from unity. If the final steady-state value of the response differs from unity, then it is common to use the maximum percent overshoot. The amount of the maximum (percent) overshoot directly indicates the relative stability of the system.

5. **Settling time, t_s :** The settling time is the time required for the response curve to reach and stay within a range about the final value of size specified by absolute percentage of the final value (usually 2% or 5%). The settling time is related to the largest time constant of the control system. Which percentage error criterion to use may be determined from the objectives of the system design in question.

The time-domain specifications just given are quite important, since most control systems are time-domain systems; that is, they must exhibit acceptable time responses. (This means that, the control system must be modified until the transient response is satisfactory.)

1.1 Second Order System and Transient- Response Specifications...

In the following, we shall obtain the rise time, peak time, maximum overshoot, and settling time of the second-order system. These values will be obtained in terms of ζ and ω_n . The system is

assumed to be underdamped.

1. Rise time , t_r

$$t_r = \frac{\pi - \beta}{\omega_d}$$

where angle β is defined in figure 3. Clearly, for a small value of t_r , ω_d must be large.

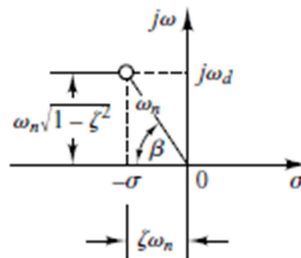

Figure 3

2. Peak time, t_p

Since the peak time corresponds to the first peak overshoot,

$$t_p = \frac{\pi}{\omega_d}$$

The peak time t_p corresponds to one-half cycle of the frequency of damped oscillation.

3. Maximum overshoot, M_p

Assuming that the final value of the output is unity

$$M_p = e^{\frac{-\zeta\pi}{\sqrt{1-\zeta^2}}}$$

If the final value $c(\infty)$ of the output is not unity, then we need to use the following equation:

$$M_p = \frac{c(t_p) - c(\infty)}{c(\infty)}$$

4. Settling time, t_s

For convenience in comparing the responses of systems, we commonly define the settling time , t_s to be

$t_s = \frac{4}{\zeta\omega_n}$	(2% criterion)
$t_s = \frac{3}{\zeta\omega_n}$	(5% criterion)

2. Higher Order Systems

In this section we shall present a transient-response analysis of higher-order systems in general terms. It will be seen that the response of a higher-order system is the sum of the responses of first-order and second-order systems.

Consider the system shown in Figure4 .The closed-loop transfer function is

$$\frac{C(s)}{R(s)} = \frac{G(s)}{1 + G(s)H(s)}$$

In general, $G(s)$ and $H(s)$ are given as ratios of polynomials in s , or

$$G(s) = \frac{p(s)}{q(s)} \quad \text{and} \quad H(s) = \frac{n(s)}{d(s)}$$

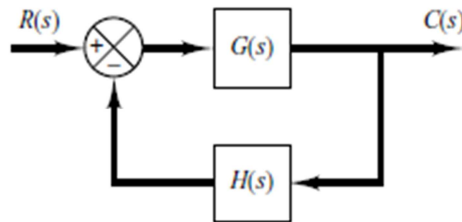

Figure 4: Control System

The closed loop T.F. of any linear invariant system can be expressed as :

$$\frac{C(s)}{R(s)} = \frac{b_m s^m + b_{m-1} s^{m-1} + \dots + b_1 s + b_0}{a_n s^n + a_{n-1} s^{n-1} + \dots + a_1 s + a_0}, \quad m \leq n$$

The factorized form is given as:

$$\frac{C(s)}{R(s)} = \frac{(s + z_1)(s + z_2) \dots (s + z_m)}{(s + p_1)(s + p_2) \dots (s + p_n)}$$

The response of the system for a step input can be:

1. Real distinct roots:

$$C(s) = \frac{a}{s} + \sum_{i=1}^n \frac{r_i}{s + p_i}$$

Where r_i resembles the residue of the i^{th} pole at $s = -p_i$.

$$c(t) = a + \sum_{i=1}^n r_i e_i^{-pt}$$

Notes:

- ✓ For a stable system, the relative magnitudes of the residues determine the relative importance of the corresponding poles.
- ✓ If there is a closed loop zero close to a closed loop pole, then the residue of this pole is small.
 - 1) A pair of closely located poles and zeros will effectively cancel each other.
- ✓ If a pole is located very far from origin, the residue of this pole may be small and its response will last for a short time.
- ✓ Pole having very small residues contribute little to the transient response and correspondingly may be neglected
- ✓ After neglecting, the higher order system may be approximated by a

Control
Mecha

Real poles and pairs of complex conjugate poles: $C(s)$ may be given as:

$$C(s) = \frac{a}{s} + \sum_{j=1}^q \frac{r_j}{s + p_j} + \sum_{k=1}^r \frac{b_k(s + \zeta_k w_k) + c_k w_k \sqrt{1 - \zeta_k^2}}{s^2 + 2\zeta_k w_k s + w_k^2}$$

This means that the factored form of the poles of higher order systems consists of first and 2nd order terms. As a result, the response of the higher order system is composed of a number of terms involving the responses of first order and 2nd order systems. The response is given as:

$$c(t) = a + \sum_{j=1}^q a_j e^{-p_j t} + \sum_{k=1}^r b_k e^{-\zeta_k w_k t} \cos \left[\left(w_k \sqrt{1 - \zeta_k^2} \right) t \right] + \sum_{k=1}^r c_k e^{-\zeta_k w_k t} \sin \left[\left(w_k \sqrt{1 - \zeta_k^2} \right) t \right]$$

which means that for a stable higher order with nonrepeated simple or complex roots, the response is the sum of a number of exponential curves (for real distinct roots) and damped sinusoidal curves (for unrepeated complex poles).

- ✓ For a stable higher order system, the exponential terms and the damped or sinusoidal curves will approach zero as $t \rightarrow \infty$ and the steady state output $y_{ss} = a = y(\infty)$
- ✓ As the real part of the poles moves farther from the origin or |real part| increase then the response of that pole decay rapidly to zero and correspondingly the setting time of that pole decrease. That is,

$$t_s \propto \frac{1}{\left| \begin{array}{c} \text{real} \\ \text{part} \end{array} \right|}$$

- ✓ The type of transient response is determined by the closed loop poles, while the zeros of the close loop T.F. do affect the magnitudes and signs of the residues of the expanded terms.
- ✓ The poles of the input $R(s)$ yield the steady state in the solution while the poles of the closed loop T.F. yield the transient response terms of the solution as they enter exponential transient response terms and/or damped sinusoidal transient response terms.

3.1 Dominant closed loop poles:

The relative dominance of closed loop poles is determined by:

- 1) The ratio of the real parts of closed loop poles

- 2) The relative magnitudes of the poles residues which depend on both the closed loop poles and zeros.
- ✓ If the real part of the closest pole to the “ $j\omega$ ” axis is (5 - 10) times less than the real part of the closest pole to this pole and there are no zeros nearby, then former pole is called dominant closed loop pole since this pole will dominant the transient response and will decay slowly.
 - ✓ The dominant closest loop poles are the most important among all closed loop poles.

3. System Identification of Second Order and Higher Order System

In the control system, the system identification process is applied to system by assume the input is step response

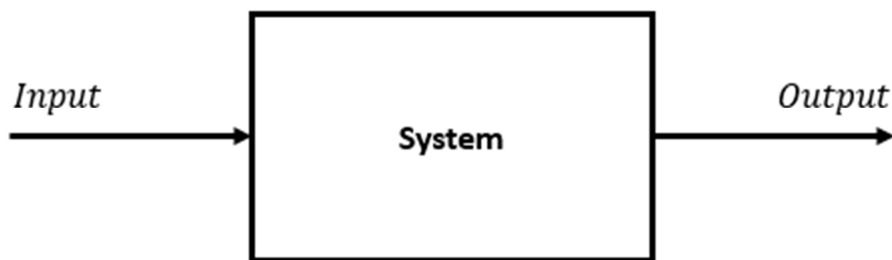

And the question now, How I can determine the transfer function of the system form measured output data ??

The step response is given in the following figure 5, and to determine the transfer function we follow the following step

- 1) Determine the settling time and the Overshoot of system
- 2) Determine the natural frequency ω_n and the damping ratio ζ

$$M_p = e^{\frac{-\zeta\pi}{\sqrt{1-\zeta^2}}}$$

$t_s = \frac{4}{\zeta\omega_n}$	(2% criterion)
$t_s = \frac{3}{\zeta\omega_n}$	(5% criterion)

- 3) The standard form of second order system is given by

$$\frac{\omega_n^2}{s^2 + 2\zeta\omega_n s + \omega_n^2}$$

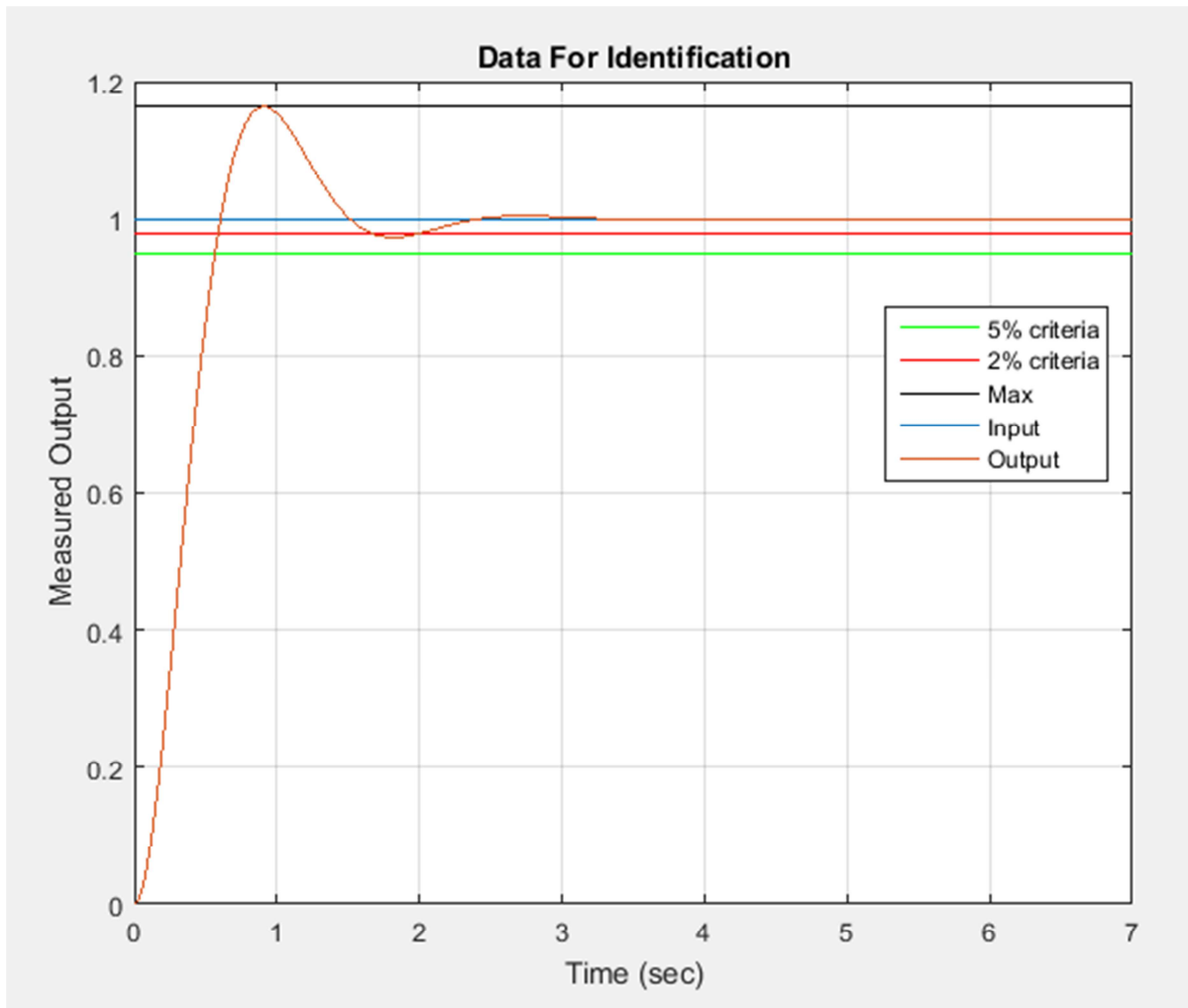

Figure 5

From the over shoot determine ζ

$$M_p = e^{\frac{-\zeta\pi}{\sqrt{1-\zeta^2}}} = 1.163 - 1 = 0.163 \quad \text{we find } \zeta = 0.5$$

And from the settling time , determine

$$t_s = \frac{4}{\zeta\omega_n} = 2 \quad \text{we find } \omega_n = 4$$

$$\frac{16}{s^2 + 4s + 16}$$

Exercises:

Exercise-1: Build the following system using Simscape:

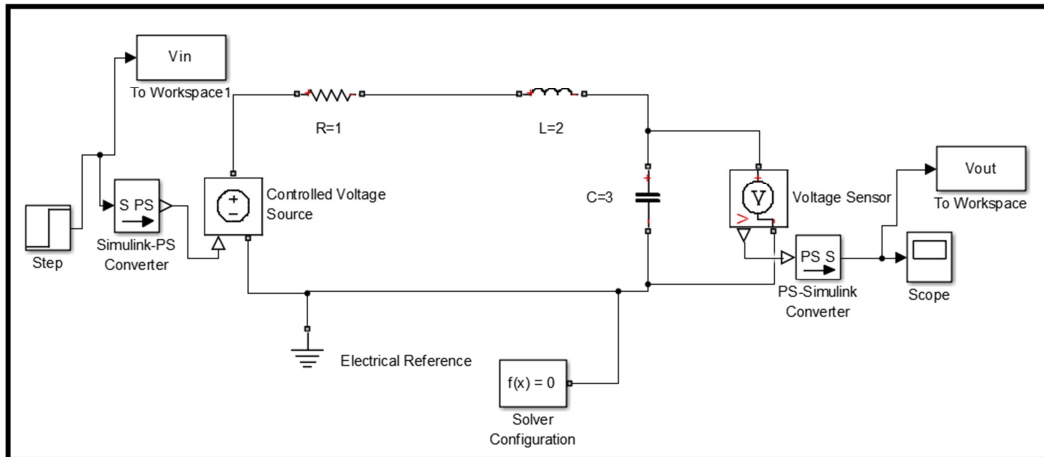

Create subsystem as shown below and suppose it unknown system:

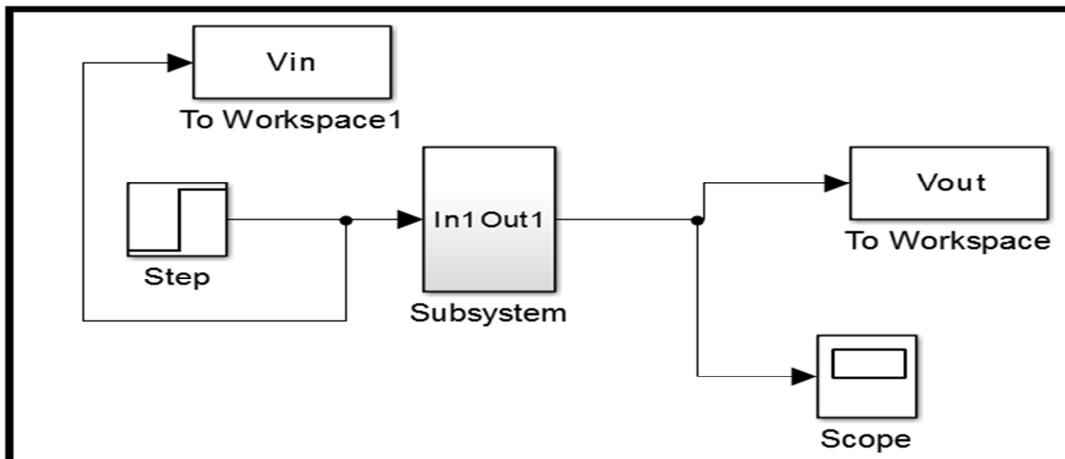

From V_{in} and V_{out} data in the workspace estimate the transfer function for the system using system identification toolbox.

Exercise-2: Build a Simulink model for the following system:

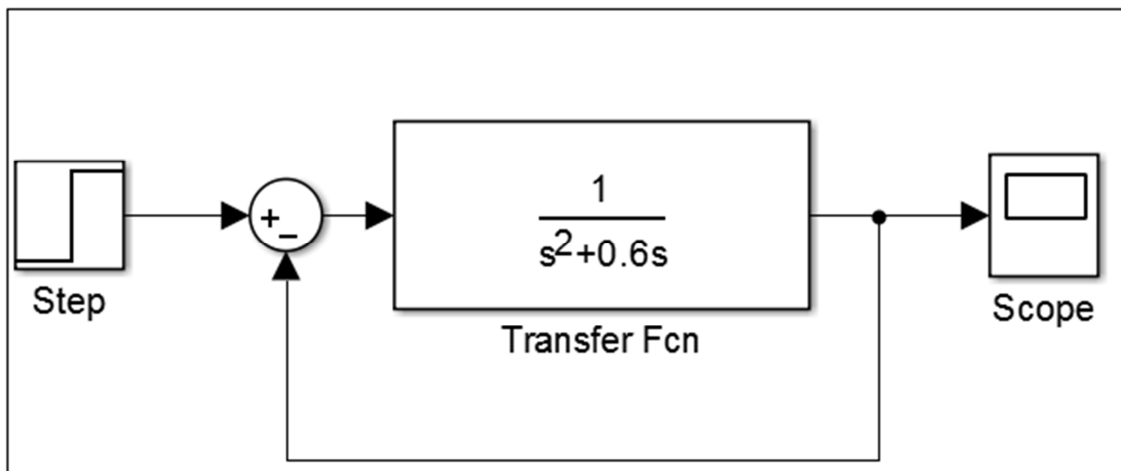

Use the output response data for identification and find the transfer function.